

OREGON WOOD WORKS

NEW TO WOODWORKING SIG

GIG LEWIS, PRESIDENT

The Beginners SIG meets every third Wednesday, starting at 7:00 PM with social time at 6:30. Please bring questions and any projects you are working on for show and tell.

We are preparing a new series of topics; keep an eye on the SIG area of the website.

The next SIG will be Wednesday March 18, 2015, a presentation on drilling by hand and power. There will be both hands-on and discussions about bit types, techniques for making straight holes with portable tools, angle drilling, countersinks and plug cutters on the drill press.

In January, Chris Mason gave a very interesting talk, and demonstrated his small table top Shapeoko CNC router, which is sold as a kit. A small router and a computer, with the necessary software, it is all that is needed to be very functional. There are many software packages available for CNC routers.

Chris designed a joint in the software and sent it to the router to cut it. The router takes away a small



amount of wood on each pass but within about 10 minutes one half of the joint was cut.

February featured Larry Wade with a very good introduction to hand saws. Discussions, demonstrations and hands-on time gave ample opportunity to try various hand saws.

Larry discussed the different types of saws and brought a number of his own for us to practice making cuts. Saws included carcass, dovetail, panel, tenon, coping/fret and flush trim. He also showed a short Chris Swartz video about the proper stance to use. Other areas discussed included the saws in the Guild shop, how saws are sharpened and how to rehab an old saw for new use.



The April SIG will tentatively feature a marquetry demonstration with Butch Miller. Watch the website for future meetings.

Ed: The New to Woodworking SIG is now one year old! Congratulations!

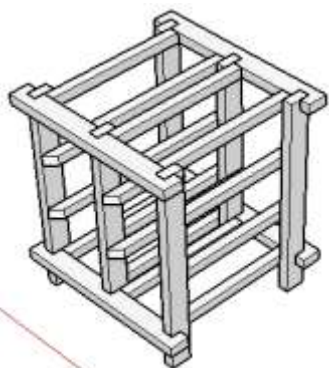

Inside this Issue:

<i>Good News</i>	2
<i>Mounting Drawer Slides</i>	3
<i>Using Custom Space</i>	3
<i>Tour of the Website</i>	4
<i>Product Build Project</i>	6
<i>Weekend Project-Wine Rack Table</i>	8

NEXT PROGRAM — THURSDAY, MARCH 12, 2015 7:00PM

BUILDING ELECTRIC GUITARS

The Guild Shop, 7634 SW 34th Avenue, Portland

At a guitar building workshop in 2010, an experienced luthier told Kieran Downes that building guitars was like "woodworking for machinists" -- dimensions, measurements, alignment, and other factors must be very precise for an instrument to be comfortable and playable and also to function properly. Mistakes in cutting frets in a fingerboard, for example, can lead to cascading errors that can render an instrument impossible to properly tune. Even for amateur players, few things are as satisfying as the first time playing a guitar you built yourself!

Kieran has been building electric guitars since 2009, starting with established body and neck designs, and moving into his own custom designs and configurations. In this presentation, he will share his beginnings and his process of building, from wood selections to final set-up.

From the west, Allen becomes Garden Home and then becomes Multnomah Blvd.

From the East, off I5/Barbur Blvd, head West on Multnomah Blvd. Then:

To locate the shop, turn uphill, North, on 35th Avenue. At the stop sign, turn right, go one block, turn left. Go over the crest of the hill and as you start down, the shop is in the little center on the right. Drive downhill to the Multnomah Art Center to park and walk back. Park in both front and back of the Art Center depending on construction.

GOOD NEWS IN THE GUILD

GIG LEWIS, PRESIDENT

There are lots of jobs getting done in the Guild and I thought that I would share some of those with all of you.



- ◆ We have 3 different organizations working on getting us a better dust collection system for the shop. Steve Poland, our Guild Secretary, has drawn a floor plan and ceiling plan of our ductwork. It is being reviewed by the businesses that do this every day and have the latest studies to support their recommendations.
- ◆ We have changed the path to getting your Green Card to work in the shop. Previously, if you were a beginner, you needed to take the 4 Machine Skills classes before taking the **Hands On Safety Test (HOST)**. We are now "Segmenting" these classes. If you **only** want to use the table saw, you can take that Machine Skills class, pass that segment of the HOST and get a card that allows you to use only the Table & Chop saw for your work. A great deal is that in this method, your \$60 class tuition will apply towards your shop user fee, too.
- ◆ You can now buy a **Single Shift** shop user ticket for \$50 for the 4-hour shift. You must still have your normal Green Card. You might only need to use the wide-belt sander or the sliding table saw. This fee is for any part of the single 4-hour shift, it cannot be shared over multiple shifts.
- ◆ We recently surveyed our 300 new members since we opened the shop, and received responses from 97 people. The skill levels were almost equally represented. An even split of beginners, Intermediate and advanced woodworkers. The Education team can really use this info in developing classes.
- ◆ We are in process for setting up a new computer system for the shop which will make things easier for the Shop Attendants to monitor several things: machine certification by member, dues are paid, and some experience background on the shop users.
- ◆ Speaking of Shop Attendants (SA's) we are training 19 more members to become Shop Attendants.
- ◆ We now have storage in our new annex for your projects. There are 32 horizontal bins and 8 vertical bins available. The rental fee for a bin is \$8 per month.
- ◆ We are going to re-start our mentoring program. We will have a list of members that can do the Coaching/Mentoring and it will be available **FREE** to the membership. Those of you that are available to help coach, please send me your name, type of wood-working where you feel qualified to help, phone number and email address. There will be no charge for this service to the membership.
- ◆ At our Summer Picnic we will be having 2 woodworking events. The first for fun will be a Two-by-Four contest. Your task will be to build something out of a

2 x 4 x 8-ft board that is useful, fun, art, furniture or whatever your whim guides you. Remember this is a FUN event.

The second event will be our Intra-Guild contest. This is the eleventh occurrence of this event, started in 2005. You will be competing against other members in your skill level. The three levels will be Beginner, Intermediate, and Advanced. We will have ribbons as prizes for the different levels, plus a Best in Show award. Think of it as a giant Show-and-Tell where you can show your family members and the other members what we woodworkers do.

- ◆ While at Northwest Woodworking Studio this last week I was reminded that Gary Rogowski has written a wonderful book on Joinery. *The Complete Illustrated Guide to Joinery* was published by the Taunton Press in 2002. It has hundreds of pictures and comments on how to do dovetails, mortise & tenons, rabbets, scarf joints, and bridle joints. This is an excellent book on the techniques of joinery. Great for Beginners and Advanced woodworkers. Also a great gift for a woodworker you know.

NEW SHOP FEATURES

BOB OSWALD

New features to help ease-of-use in the shop were recently introduced. Storage space rental for your projects and purchase a single shift of shop time. Guidelines are posted on the website, Our Shop / Buy Shop Time. See a condensed summary below:

Buying Hourly Shop Time

- Purchase a full shift of time using the PayPal
- Shop attendant punches your receipt and files it.
- All shop time is per the shifts defined on the website
- There is no shift overlapping
- Drop in at any time during the shift and spend the remaining time with no carry over.
- Must have a "green card".

Storage Space Rental Guidelines

- Buy a shop rental space using PayPal
- Shop manager will designate an area for you
- Purchase is in one month blocks, one time or recurring.
- Storage time begins on the date of the invoice and ends on the same date the following month
- Post your receipt on your storage location
- Access the storage area during normal hours when the shop is open with a shop attendant on duty.
- You are responsible for remembering the storage contract and either renewing or removing your things. Left over items beyond some reasonable expiration time will be removed, confiscated and used, or destroyed.
- Limited to a maximum of six months of storage on any one project.

MOUNTING DRAWER SLIDES

BOB OSWALD

How many jigs are on the market to hold drawers and slides in position to mount them properly? Several. How many have I purchased over the years to get this task done right? All of them. How many do I use now that I know this simple approach that an eighth grader can use? None of them.

The hardest part is determining where you want the drawer located vertically. For the dresser pictured, I wanted the bottom of the drawer located 1/4" above the cross rail.

Position of the slide itself

There are two factors to consider. Most important is where on the drawer side to position it. I choose a couple of inches (or so) above the bottom. It doesn't matter. Second is checking where this lands on the cabinet side. You may have to mount spacer rails if you're using a face frame to shim out flush with the edge of the face frame.

Take the slide apart.

On the cabinet side, draw a slide center line where it will attach, front to back and square. Center the cabinet half of the slide on the pencil line flush with the front of the cabinet.

On the drawer side, draw a slide center line where it will attach, front to back and square. Center the drawer half of the slide on the pencil line flush with the front of the cabinet.

Note that the mounting directions are identical. The only trick is to position the lines properly. That's done by measuring the drawer position up from the bottom. Then measure the cabinet position up from the rail plus 1/4" I use a scrap of plywood ripped to the correct drawer vertical space width. For the cabinet, add a 1/4" square spacer stick to shift the cabinet slide position.

Want to buy a drawer alignment jig?

USING CUSTOM SPACE

BOB OSWALD

As woodworkers, we have the unique ability to make things fit. We can create a piece of furniture that you could not buy at a reasonable price.

A closet in one bedroom has some built-in storage and a little area in the center was going to waste, used for hanging shirts. There was plenty of hanging space above and no decent drawer storage. A dresser in the bedroom was taking up a large amount of space. "Honey, would you build a dresser like that one but that fits in the closet space?" she says. "Sure. I'll probably need a couple of new tools but no problem." he says.

It's pretty standard construction, built over a couple of weeks. Made of Cherry, it fits with 1/4" clearance all the way around. This required care in measurement and execution of course. The final piece fit as planned.

The cabinet is a box, no face frame. A few rails across the middle form the background for the gap between drawers. The drawers are boxes, dovetailed, of course, because that's what we do. Full extension drawer slides add the right touch of class.

I made a tactical decision to build this as to NOT use the tabs on the slides to adjust for left-to-right spacing. Normally one would not do this, because it means that the drawer width must be exact, or at most 1/32" narrow. Definitely not 1/16" too wide. And since they are dovetailed, the cuts must be made so the pins and tails are exactly flush, not changing the width of the drawer. ***All it takes is care, attention to detail, measure ten times.***



SHOP TOURS THIS SUMMER

ALEXANDER ANDERSON

In April the Guild will help in facilitating an open shop tour of member's shops. This will be a time to open your shop to other guild members and share some of what you do in your shop and how it is laid out. And this will be a time to get ideas from other Guild members about how to get the most out of your shop.

We are setting times and are hoping to have the tour span a couple different weekends for different sections of the region. This would allow people with an open shop to also get out on the tour and see other shops.

If you are interested in showing off your shop and sharing some of the ideas of organization and layout that work for you, please contact Alexander Anderson at alexander@madronestudio.com or feel free to call, 503-583-4423.

Please note - do not feel the need to have the perfect or the ultimate shop to show. We learn from each other by seeing what can be done in a variety of spaces. We dream about having as much space as Norm or are amazed and inspired by how to pack so much into a half garage. Go ahead and sweep the floor and put away a few things (if you want to).



The slides were also mounted to the cabinet sides and the drawer sides using a technique the kids are taught in the Gaston High School woodshop. See a separate article in this issue for that technique.

They fit. Everything fit. I'm so proud and so delighted.

I can say with great pride that all five drawers fit without any adjustment to the slides.

A TOUR THROUGH OUR WEBSITE-SOME PIECE FOR EVERYONE

BOB OSWALD

We have many new members and a somewhat dynamic Guild shop these days. The website is slowly morphing on a weekly basis, hopefully slow enough and improving in intuitive use that you find it a good rather than a bad experience.

It seemed appropriate to give you all a little overview of the Guild website. This website is our major means of communication, data management and scheduling for everything we do. At least half of the pages should be of interest to the general member. Monthly Programs and the Newsletter should be of interest to everyone at least once a month. Resources, on the other hand, might be less used, but let's look at a few highlights you might appreciate.

Website Design

The website is designed with on-line tools hosted by a company called Wild Apricot, based in Ontario, Canada. This method was chosen rather than designing using code such as WordPress to make it easier to transfer to a different website manager, not requiring programming skills. There were many presentation formats available. I chose what you see.

A new page is very easy to create, with immense flexibility. The pages are easy to re-sequence and rename. One must resist the urge to constantly juggle the appearance and frustrate the users.

Home page

The home page is the starting point and most global view. I've tried to keep this design clutter free. So many websites try to put virtually everything on the home page, with equally cluttered sub-pages. I hope you find it easy to use.

The major functions of the Guild are displayed on the home page, each in a box with a title. A box for Green Card events was recently added to make it easier to find them. Changes to improve the HOST scheduling are being discussed.

A limited number of the upcoming events are displayed on the home page. For a complete list, click on the title of the box. Click on an event name to get a detailed description, either in the home page box or on the total list page.

Most of the features of the home page are visible to the public. As a member, you do not need to log in to see the most common features such as

the next program or classes available. However you must log in to register for classes, use the features of the shop and access the members only section.

Log in as a Member

You log in with your email address, which the Wild Apricot system requires to be unique for each person. The first time you ever log in, you have to pass the "read the strange characters" screen. At that point, you set your password and log in as like most other sites. If you lose or forget your password, there is a reset feature. If you're really lost, write to the website administrator. There is a link is at the bottom of the home page.

Your Profile

Each member record contains your contact information. While it's not mandatory (required field) to fill in everything, if we don't know where you live, you won't get membership cards, green cards, shop time purchase cards, etc. Do you know that the Guild guards this information jealously? We do! It is never used for marketing type uses and the public does not have access to it. Members can contact each other and we are depending of course on the integrity of our members to use this information only for personal contact. It says so on the website,

A variety of personal information is collected when people join. We like to know how you heard about us because it helps us to understand how to better address perspective members. We need to know your skill level to guide our safety and insurance programs.

We send occasional "guild wide" emails. One is notification of the newsletter. Others are optional and are choices you make. Filters in the database limit who gets certain kinds of emails. It IS possible for an administrator to use the wrong filter, or even send something to the entire membership. If you think this is ever abused, please notify the web manager. Currently there are three filters:

- ◆ *Notify me of bargains:* Really good deals, especially free things. Like a closeout of lumber or a tree down with free wood, time critical events like a member closing out a shop. There is a buy/sell forum also available where you can advertise things for sale.
- ◆ *Notify me of job opportunities:* A variety of woodworking jobs come to my personal attention from my contacts in the area. As a service to our members and the public, if it's a job I don't want to do myself, which is most of the time now, I'll pass it on. Do know that I promise the customers that I put complete trust in any Guild person who responds, to do quality work at a fair price and always, always, always leave the customer happy. I do get some feedback and I do care very much if this service gets abused.
- ◆ *Notify me about classes:* The Education Committee notifies you occasionally about upcoming classes.

It is very important to me as the web manager, that Guild email doesn't get a reputation of being 'spam'. I detest it in my own mailbox and hold the same standards for you.



When you join, these flags are turned on by default. You can change them at any time that you don't want to receive one or more of these notices. To do this you would log in. **Next to the log in box in the upper right is a "View Profile" link.** When you click on that you'll see all the information in your record. Click the edit button there to change things. Note that some fields are *required*. If you joined a long time ago and want



My profile



to change something, you may have to fill in a required field that didn't exist when you joined. Watch for them. The site won't let you save your changes until all required fields are completed.

Membership

Always interested in new members, this section is at the top of the list. New people join or you renew your membership here. When your membership expires, quite often the website, through automated email to you, will take you inside to make it easy to renew.

About Us

Next in significance is the purpose of the Guild and our commitment to fair treatment of all members. You can also find the current Board of Directors and the various committees and support roles. Currently Guild clothing and merchandise is available for purchase here. This will move to a better location on the website one day.

Newsletters

The monthly newsletter exists to keep you updated on events and functions in the Guild. We try not to announce things to a limited audience at the monthly program that affect the Guild as a whole, reserving that for the newsletter. The current newsletter is available for the whole world to read, unlike many clubs that jealously guard their newsletter. It is a major selling tool for new members. The past newsletter archive is accessible to members only. Newsletters are written off-line using Microsoft Publisher, converted to PDF and loaded on the website each month. PLEASE feel free to contribute your own items of interest.

Monthly Programs

The next most important function of the Guild is getting together to share ideas, meet people, make friends and learn more about woodworking. This monthly program task is managed by the Meetings Chair. The next three programs are listed on the home page. For a new upcoming program, an event is created for that date and automatically appears in the list in chronological order. Past events disappear.

Classes (Education)

A major purpose of the Guild is education in the form of

classes, both demonstration and hands-on. Sub-menus take you to views that summarize our major programs. The main menu entry is the listing of all classes currently scheduled. Every class remains in the database for access to our history.

Shows

When the Guild participates in an art or woodworking type event such as Gathering of the Guilds, Oregon State Fair or Salem Art Festival or the Woodworking Show, the event details appear here. Participating in a show is a significant event, requiring volunteers, Guild supporting furniture, load in and out, setup and managing our presence in that event. You'll see details about the show as well as requests for volunteer help, which usually means free admission.

Library

The library used to be manually transported to Guild monthly programs by hand truck loads of boxes. One day the new shop will house a set of shelves and ability to check out books at the shop. Meanwhile, a complete listing of our literature is maintained on the website by our librarian. You can reserve a book and have it brought to the next meeting.

Our Shop

What a major undertaking this single menu entry represents. A look at the sub-pages under this title suggest that there's a lot going on here. There is. This page and all of the functionality below it was created in 2013 when we acquired the current shop. It changes often as we refine the operation of the shop and add features.

In this section you would learn the qualifications to work in the shop and the various steps to obtain your "Green Card", your ticket to be authorized to be in the shop. In this section you also purchase shop time and schedule shifts when you want to use the shop.

Half of these menus are visible to members only. You must be logged in as a member. One sub-menu is only visible to Shop Attendants, the people who are in the shop to oversee your safety. They are assigned by the shop manager and website manager to a group by that name. Their own web page provides listings of members qualified to use the shop.

Opportunities

This page explains places where you can expand your woodworking skills (for free). Helping the Guild always leads to helping yourself. The Guild is run 100% by volunteers. No one receives any form of compensation. We are truly 'member owned'. We can always use help; take a look.

One of the best ways to learn more about woodworking, first-hand and hands-on, is by helping on a Community Project or building items with the Product Build group.

Calendar

This is an overall view of *every* event scheduled in the Guild website including programs, classes, shows and SIG meetings. I've debated removing it to simplify the site and perhaps reduce confusion about this versus the shop calendars.

(Continued on page 6)

(Continued from page 5)

I wonder if anyone uses this page??

Sponsors

Check on this list of commercial folks who support the Guild in some form, usually with some kind of merchandise discount. Stop by here for a quick link to their website.

Professional Member listing

If you are registered as a professional member and if "Include in professional directory" is checked in your profile, which it is by default, your name and contact information appear here.

Professional members can also have a gallery page. The gallery starts with a thumbnail view of each professional member who has a gallery page and includes a link to their detailed page. Unfortunately the website tools are quite cumbersome to use, so you need to send the web manager a request for a page and appropriate details which are then configured for you. Take a look at some examples. You do have to be a paid up member to appear here. If your membership expires, your listing and your gallery page disappear, to re-appear automatically with your dues renewal.

Forums

This section was requested so often in our prior website. We finally acquired the capability to have forums and sadly they don't appear to be very much used. It's easy for me to create a new forum, rename or re-sequence them to make them more intuitive or appealing. Just let me know.

Quite a few topics were implemented based on a few people's vision. Sadly the Wild Apricot system does not provide for "aging" capabilities, like displaying only the last 30 days of a posting. So "for sale" items, for example, remain forever until I or the originator delete them.

Members Only

This page is only available after you log in with your email address and password. Want to know how to contact another member? What's going on behind the scenes on the operation of the Guild? Look here..

THE PRODUCT BUILD PROJECT

ED FERGUSON

One of the Guild's service activities is the Product Build Project. The group participating in this project makes wood products that are donated to worthy causes, such as Toys for Tots, or sold at various venues, such as the Gathering of the Guilds. All proceeds from sales go to support our Guild programs. In the past year, the Product Build group has made boxes, step stools, doll cradles and end grain cutting boards.

This is an ongoing project and new participants are welcome. It's a good opportunity for members... whether highly skilled or beginning woodworkers... to get acquainted with the Guild Shop, work with other members on a project that benefits the Guild, and enhance their woodworking skills. It is also an opportunity to develop machine skills needed for Green Card certification. As with other community projects, there are no shop fees for participation.

The Product Build Project has standing shifts in the Guild Shop on Wednesday afternoons from 1:00-5:00pm. You are welcome to drop in on a session and introduce yourself. If you have any questions about the program, please contact Ed Ferguson at edbikes@comcast.net



Chuck Wissler, Bob Sokolow, Leslie Faus and Phil Scott consulting on doll cradle construction.

CELEBRATE OPEN HOUSE CP

JOE SANDERS

The dresser project for Open House Ministries is near completion. Yes dresser number 30 will roll off the production line by the end of February!!

We would like to include anyone who had a hand in completing this large commitment by the Guild of Oregon Woodworkers. Please notify Don Cline if you would like to be on the mailing list for the upcoming party to celebrate this achievement. A large number of members have donated time to the goal over the last several years and this deserves a toast to anyone who has been involved.

Contact Don at dclinesan@gmail.com
Celebration details to follow based on participation.

WELCOME NEW MEMBERS

BOB OSWALD

Welcome to our latest new members in chronological order:

Chris Heineman, Joe Zauner, Eric Dunder, Dan Silvernail, Merle Mattson, Steven Walgrave, Risha Kelley, Powell Houser, John Jaramillo, Doug Engebo, Joe Thiele, Lane Barton, Hari Dass Khalsa, Ray Schadewitz, Jim Bartels, Charles Guerin, Rod Steinbacher, Jim Dismore, Michelle Cooper, Richard Schiffer.

We hope you'll make a regular appearance at the monthly programs. We're happy to have you with us. Say hello to an officer at the next meeting so we can get to know you.

MORE HOST SESSIONS

BILL KEAY

HOST Sessions:

Two Hands On Safety Test (HOST) sessions are scheduled for March, for those people needing this certification to begin using the Guild workshop.

Tuesday, March 3rd at 5PM
Saturday, March 14th at 9AM

Space is limited, so please visit our reservation page to get signed up. On the website, Our Shop / HOST-Scheduling Contact Bill Keay (wkeay@comcast.net) with any questions.

VOLUNTEERS—TOP PRIORITY

BOB OSWALD

You see this reminder and request quite often. The Guild is all volunteer and we can definitely use help in a lot of places. The most urgent needs include:

- ◆ Help the membership chair bring new members into the Guild. This involves printing membership cards and training to use the website features for accepting new members. We would like this person to take over the membership chair role over time.
- ◆ Organize our monthly programs. We are currently schedule with events for most of the rest of 2015. But there is a great need for someone to keep this wheel rolling. I did the task for two years while serving as President. It turned out to be surprisingly easy and very rewarding. Any time a few ideas were needed, a bunch of board members could, in a matter of minutes, come up with a dozen ideas. You'll treasure the friendships and contacts you make in this task.

PLEASE !

BOB OSWALD

Cell phones, a blessing and the biggest curse the world has seen. This topic has not been much of a problem in the Guild, until recently. If only 1% of people at our meeting forget to turn off their phones, our larger numbers are making these interruptions worse.

Haven't cell phones and the reminder concept been around long enough now that it should be more automatic to silence them?

In our last Guild meeting I heard phones go off at least three times. Two people left the building to answer. One person answered it, talked for almost a minute, and finally had to be asked to take it outside.

I have this personal outlook on life that I know not all of you will share. You do not have to be in constant communication with the world every second of the day. Take an hour off, turn off the phone, relax and enjoy what you came for.

Please help us be a friendly and respectful organization. PLEASE don't make us start printing signs.



GATHERING OF THE GUILDS

ARIEL ENRIQUEZ

Volunteers needed April 22 – 26 (No experience required!)

Hello fellow Guild members!

The time is coming soon for the annual Gathering of the Guilds show. Once again we're turning to all of you to come help make the show a rousing success. We know you won't let us down. This show happens over 5 days (April 22 – 26); 2 days of set-up and prep and 3 days of show time. Our volunteers help out with all phases of the event.

Wednesday and Thursday are "Load-In" days. This is when the vendors move their gear in and set up their booths. During load-in our volunteers work by helping in transport of all items from the loading area to the individual booths. We have hired some massive carts from the show decorators just for this job. This isn't as onerous as it might sound. In fact, it's quite a fun and interesting time. You get to meet master artisans in metal, glass, weaving, beads and, best of all, the wood people. All of them are tops in their craft and VERY appreciative of the load-in helpers.

Friday, Saturday and Sunday are "Show Time". The hall opens to the public and sales get underway. Our volunteers serve in various ways at this time. You might be assigned to our Guild Headquarters booth where basically you represent the Guild, answering any questions that a patron might have about our club. You might also be asked to watch one of vendors' booths when they need to take a break. You might also be asked to "man" the entrance doors with a counter in your hand to help keep tabs of the size of the crowd in the room. You might be asked to relieve Jim Madaras in the Member's Booth, a space we have dedicated to non-professional members who want to try their luck at selling their woodcrafts.

By the way, taking part in the Member's Booth is a **free** benefit available to any and all non-professional members. You **do not** have to volunteer at the show to take advantage of this. We do, however, ask for a 15% cut of any sales you make. The proceeds go directly into the Guild treasury. Good hunting!

There are always small tasks that might be asked of you but let me assure you, this is a **gravy job**. **All we ask is a 2-hour commitment from you.** Of course, you don't need to limit yourself to just the minimum. You might try a load-in shift and a show-time shift and get to see all the workings of this event. It will amaze you. Come join the happening at the Oregon Convention Center.

Please contact me at arielyphyllis@gmail.com. Or leave a message at 503-286-4828.

I thank you in advance for stepping up! Hope to hear from you soon.



WEEKEND PROJECT—WINE RACK END TABLE

BOB OSWALD

This cute little Wine Bottle End Table was an inspiration a couple of years ago, lost in fuzzy memory. I made another one this weekend for a friend. Cherry and mostly off cuts from the scrap barrel. There are five types of pieces not counting the top. You can pre-cut all the pieces and then assemble like a kit.

From the exploded parts view, left to right

Item	Quantity	Size
Bottle Rail, Short	8	3/4 sq x 10 1/2
Bottle Rail, Long	8	3/4 sq x 12
Stile, Short	2	3/4x1 1/2x13
Stile, Long	4	3/4x1 1/2x15
Rail	4	3/4x1 1/2x13 3/4

Consider cutting the short bottle rail 1/4" longer to allow the long bottle rails to be set back slightly from the edges for better appearance.

The long bottle rails are miter cut on each end. The top and bottom rail sets are notched 3/4" deep and 3/4" wide to accommodate the stiles. I didn't overlap the notches like an "egg crate". There is a lot of side glue surface if your stiles fit tight, so it's plenty strong.

Assembly is all glue. Recommended sequence is:

1. Glue the front top and bottom rails to the stiles. The middle stile is 2" shorter and sets the location of the bottom rail.
2. Glue up the back rail and stiles the same way.
3. Clamp a short bottle rail in each corner, clamping each end of each rail against its companion outside stile. It starts out awkward but you can loosen clamps and adjust

4. as you proceed around the four corners.
4. Make sure that everything's square and clamps are tight.
5. Remove one short rail, glue and re-clip.
6. Proceed with the other three short rails.
7. Glue on the long bottle rails in any convenient sequence. Set them flush front to back and 3 1/2" spaced inside to inside. With the longer short bottle rail, set them back 1/8" from the edge.
8. My finish is wipe on/off varnish.

The simple, clean lines go well with most any furniture. One sits on the front porch for those evening relaxation moments in the setting sun. Perhaps a good project for the Product Build group? Easy, fast and teaches lessons in accuracy.

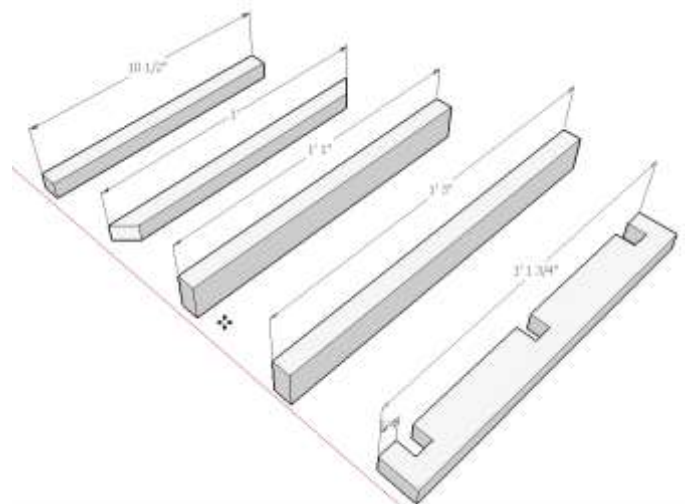
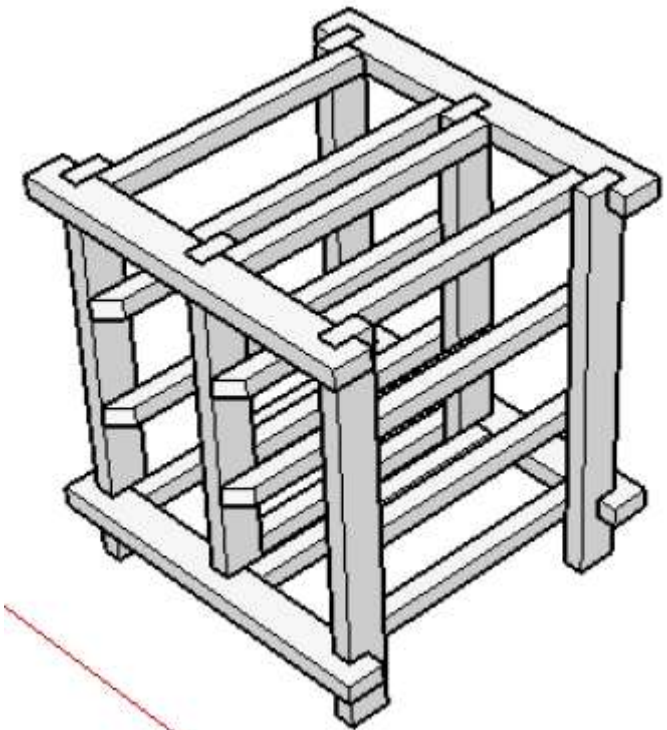

ART SHOWS UPCOMING

BOB OSWALD

Attention professional members, and folks looking for a place to see some fine woodworking and other arts. Here are a few events this year that have come to my attention.

Artists Outstanding in Their Field. Damascus, OR

August 16, 2015

<http://www.outsideinstyleglass.com/>

Art & Soul of the Magic Valley

Twin Falls, ID April 17 – May 2, 2015.

www.magicvalleyhasart.com

The Magic Valley Arts Council is seeking artists for the 2015 Art & Soul of the Magic Valley, the largest art contest in the Northwest, now in its 5th year, is a unique community-wide art contest, where public-voting determines the recipients of cash awards to 21 winners. Artists compete for \$34,000 in prize money. Grand Prize is \$10,000.

New to the contest this year is \$1,000 will be awarded to the Best in Show of each category – and woodwork is one of the categories. Currently only six woodwork artists are entered. The Best of Show Winners are determined by public vote.

*Categories are listed on Application. Artists Entry Fee is \$75 until February 28, 2015. Apply as soon as possible and use code PRIZE after the deadline until March 6.

ArtBurst NorthWest 2015

Marylhurst University, August 1 & 2, 2015

Application Deadline: May 10, 2015

A juried exhibition and sale of fine arts and crafts. Designed, planned and produced by artists for artists, ABNW features over 100 highly qualified local and regional artists. We invite artists in all media to apply to this celebration of creativity to be held August 1-2, 2015 on the campus of Marylhurst University. Application and prospectus are available online at ZAPApplication.org through May 10, 2015. See more information at www.artburstnw.org.

A SKETCHUP TIP

BOB OSWALD

SketchUp is a very popular and powerful drawing tool. Many of you know about it. Some of you use it. The free version will do everything you as a non-business user will need. Have you used the Scale tool?

I learned years ago from Lloyd Johnson how to use it to mirror a copy of an object, like a tapered table leg, so that the copy properly reflects the original. Fold the object inside – out using the side center handle. Then type -1 <enter> to get a perfect mirror image.

BOARD MEETING MINUTES

The Board of Directors of the Guild of Oregon Woodworkers meets monthly before the general meeting. Minutes of this meeting are available on the Guild website at www.GuildOfOregonWoodworkers.org
Click the “Board Minutes” entry under Members Only.

FROM THE EDUCATION TEAM

NORM BAIRD

GUILD UPCOMING CLASSES

We are now scheduling the four Machine Skills Classes, in support of the Hands On Safety Test and the Green Card, one session for each class each month. Check on the website, under Classes.

Designing With Wood: Selecting the Best Material for Your Project, with Jeff Zens

March 14, 9-5, \$120

MAC Cottage 5

Coordinator: Sean Ben-Safed

Sliding Table Saw Skills, with Alexander Anderson

March 17, 9-1, \$60

Coordinator: Doug Drake

Practicing the Fundamentals, with Larry Wade

April 4, 9-2, \$50

Larry's shop, north of Beaverton

Coordinator questions to Larry

See the Guild website for registration and details. Contact the Class Coordinator with questions. All classes are held at the Guild shop unless otherwise specified. 7634 SW 34th St, Portland, OR 97219

AFFILIATE UPCOMING CLASSES

See their websites for more details and offerings

Northwest Woodworking Studio

The Hand Tool Shop: Carving and Shaping

April 20-24

Instructor: Gary Rogowski

Portland Community College

PCC offers woodworking classes for beginners, and basics.

Also special classes for women and seniors. Registration for spring term begins on March 4.

GUILD OFFICERS—2015

BOARD OF DIRECTORS

Officers:

President – Gig Lewis

Vice President – Alexander Anderson

Treasurer – Roger Crooks

Secretary – Steve Poland

Committee Chairs:

Membership – Larry Wade

Education – Chip Webster

Programs – Jim Madaras (seeking replacement)

Shows - Vacant

Operations – Ray Curtis

Communications – Bob Oswald

Community Projects – Don Cline

Sponsors – Bob O'Connor

Prof Membership at Large – Bill Bolstad

General Member at Large – Norm Baird

The Guild of Oregon Woodworkers is a group of professional and amateur woodworkers committed to developing our craftsmanship. The Guild offers many benefits for members, including:

- Monthly educational programs
- Monthly newsletter
- An education program to help members develop woodworking skills
- Sponsor discounts
- Woodworking shows
- Network of business partners (the key to our development as members and as a Guild, providing additional learning opportunities)
- A woodworking shop with space to rent
- A network of friends

For information on how you can become a member, see the Guild website listed below.

GUILD OF OREGON WOODWORKERS

10190 SW Washington St., Portland, OR 97225

CLASSES, SEMINARS, DEMOS, AND SUCH

Northwest Woodworking Studio 503-284-1644, www.northwestwoodworking.com

Rockler Woodworking 503-672-7266, www.rockler.com

Oregon College of Art and Craft 503-297-5544, www.ocac.edu

Woodcraft 503-684-1428, www.woodcraft.com

Woodcrafters 503-231-0226, 212 NE 6th Avenue, Portland, www.woodcrafters.us

THE GUILD IS PROUD TO BE SPONSORED BY:

Barbo Machinery
Carbide Saw
Emerson Hardwood
Goby Walnut Products
Hardwood Industries
NW Figured Wood
Rockler Woodworking
SawStop
Woodcraft
Woodcrafters



Affiliates:

Northwest Woodworking Studio
Oregon College of Art and Craft

- ◆ Some sponsors offer discounts to current Guild members.
- ◆ ** denotes Scholarship Sponsor



Guild of Oregon Woodworkers

c/o Bob Oswald
40639 SW Vandehey Road
Gaston, OR 97119



We're on the Web!

www.GuildOfOregonWoodworkers.org